



# **MICRO GROW**

## **GREENHOUSE SYSTEMS, INC**

26111 YNEZ RD., SUITE C-4, TEMECULA, CA 92591 PHONE (909)-296-3340 FAX (909)-296-3350

Rev. 1.2    11/13/01

**Growstat Series**  
**Ventstat**

# GENERAL INSTALLATION PROCEDURES

## PANEL MOUNTING

Mount the control panel in an accessible location. Make sure that the location is free of vibration and in close proximity to the devices being controlled. Always consider voltage drop of electrical current when locating the control panel. Securely mount the panel.

## SWITCHING CONTACTORS AND RELAYS

The control panel will operate the greenhouse equipment via load contactors and load relays. **ALL RELAYS AND LOAD CONTACTORS USED MUST HAVE A SURGE SUPPRESSOR INSTALLED ACROSS THE COIL OF THE RELAY OR LOAD CONTACTOR.** These surge suppressors are readily available from Micro Grow Greenhouse Systems, Inc. All load contactors and relays are also readily available from Micro Grow Greenhouse Systems, Inc. To decide which to use, follow this guide:

### **LOAD CONTACTORS:**

Exhaust fans, pad pumps, horizontal air flow fans, heating pumps, fan jets, large heaters, crop lighting, and all other larger electrical loads over 1/6 H.P.

### **LOAD RELAYS:**

Signal switching such as the small control lines for gas fired heaters, control lines for vent and shade system controls, small loads such as motorized shutters, other loads up to 1/6 H.P.

### **CUSTOM CONTACTOR AND RELAY PANEL AVAILABLE**

A custom-built load contactor and load relay panel is available from Micro Grow Greenhouse Systems, Inc. This panel will contain all of the required switching apparatus for your project, as well as a correctly sized machine tool transformer. Contact Micro Grow Greenhouse Systems, Inc. for pricing and availability.

## TRANSFORMERS

The control panel will be powered by a 24 VAC transformer. It is most important to use a MACHINE TOOL TYPE. A Machine Tool Transformer is a heavy-duty variety that will allow for high inrush currents that are associated with the use of load contactors and relays. Micro Grow Greenhouse Systems, Inc. stocks these types of transformers. Use no smaller than a 50 VA Machine Tool Transformer. For a system that has more than three load contactors connected, use a 100 VA Machine Tool Transformer.

## ELECTRICAL CIRCUITS

The electrical circuit that feeds the machine tool transformer must have no other loads connected to it. This will prevent damaging surges from other related electrical devices. Follow all local and national codes in the connection of all of the greenhouse equipment. Always allow for voltage drop conditions. Always consider that the greenhouse is a wet environment. Always follow the code rulings for disconnect switches and over-current devices on greenhouse equipment. **USE A QUALIFIED AND LICENSED ELECTRICIAN AT ALL TIMES.**

## WIRING METHODS

Always use stranded wire when connecting cables or conductors to the actual circuit board of the control panel. This will allow flexibility. Use no smaller than #18 gauge, stranded wire for all outputs. Use no smaller than the recommended wire size of stranded cable for inputs (generally #22 gauge).

### SENSOR CONDUCTORS:

Route sensor conductors separately from control conductors. This is very important so as to reduce electrical interference. Never route sensor conductors in conduits used for other voltages. This is in violation of the electrical code and will cause dangerous interference to the control system. Always locate the actual sensor in the center of the range that is being controlled for accurate readings. Do not allow the sensor to come in contact with any greenhouse structure member such as a post that would give off any radiated heat and cause a false temperature reading. Do not locate the sensor where a particular piece of equipment would cause false readings, such as a heater blowing directly on the sensor. Mount all wind/rain sensor in a clear area, free of any wind obstructions.

### CONTROL CONDUCTORS:

Route all control conductors separately from sensor conductors. This is very important so as to reduce electrical interference. Control conductors may be routed in conduits that contain other power system wiring only if the insulation material on the conductors is the same as the power system wiring. Consult the national electrical code or local codes if in doubt about the insulation ratings of the wire in use. Remember, always use a qualified and licensed electrician.

## VENT SYSTEMS, SHADE SYSTEMS, ROLL UP CURTAINS

When connecting a vent system, shade system or roll up curtain ventilation system to the control panel, you must use a separate control box designed for that particular vent or shade system. These are readily available from Micro Grow Greenhouse Systems, Inc. Generally these separate control boxes feature over-current protection for the particular motor on the vent or shade system, provisions for direct limit switch connections, and a manual means of operating the vent or shade system independent of the main control system. These separate control boxes will connect the main control system either directly through the outputs of the control system, or they will require control relays for interconnection to the main control system. Consult the individual instructions that come with the vent or shade controls for detailed information.

## SYSTEM TESTING

It is always important to completely and fully test the electrical system by energizing circuits and verifying equipment operations before automatically operating the equipment from the control panel. This would include setting all of the vent and shade limit switches at the individual control panels.

# Ventstat Operation and Configuration

## Features:

- ✿ Safe, Low Voltage Operation (24VAC)
- ✿ Large, Easy-to-Read Front Panel LCD Display
- ✿ Digital Accurate Microprocessor-based Control System
- ✿ Easy-to-Use Front Panel Program Switches
- ✿ Manual Over-ride switches for all Outputs
- ✿ Weatherproof, Clear Face Enclosure with Lockable Cover
- ✿ High/Low Sensor Memory for the Past 24Hours
- ✿ Separate Day, Night and DIF Setpoints
- ✿ Digital 24 Hour Internal Clock
- ✿ Optional Weatherstation Over-ride Connections
- ✿ Includes Precision Temperature Sensor
- ✿ Includes Photocell

## Description:

The Ventstat control operates one set (open/close) of roof vents, side vents roll-up curtains or retractable roofs. It will operate in up to eight stages without using inter-stage mercury switches.

## Configuration:

### Hook Sensors

#### Verify Switch settings,

Set Temperature:

1. Depress the **SET** switch once. The **TEMPERATURE** indicator will be on. Use the **VALUE** switch to set the correct desired setting. This will be the day mode setting. Depress the **SET** switch again to light the **NIGHT** indicator along with the **TEMPERATURE** indicator. Set the desired night level here.
2. (If DIF is not used, this instruction will not apply) If DIF is being used, the temperature setting for the DIF time period will be set next. Continue to depress the **SET** switch until the "**DIF**" appears on the display. The control will show the DIF temperature. Use the **VALUE** switch to set the desired DIF temperature.
3. Return to the run mode by toggling the **RUN** switch up.

#### To Check High and Low History:

The control will automatically track the high and low readings for the past 24 hours for both inputs. To check them, depress the **SET** switch until the word "**HIGH**" appears in the display. The control will automatically indicate the highest reading for the past 24 hours. Depress the **SET** switch until the word "**LO**" appears in the display. The control will automatically indicate the highest reading for the past 24 hours. If you would like to reset these values, depress **VALUE** switch once while the system is in the high and low mode. The system will however automatically update these readings continuously.

## First Time Setup

To Set the Vent Timing:

1. Continue to depress the **SET** switch until the word “**OPEN**” appears on the display. The control will be switching between the word “**OPEN**” and the opening time of the vent. The opening time of the vent is the time in minutes and seconds to take the vent to go from fully closed to fully open. Use the **VALUE** switch to raise or lower the flashing value. The first value will be minutes. Depress the **SET** switch again to set the seconds.

To Set the Vent Positions:

1. Continue to depress the **SET** switch until the **POSITION** indicator is on. The display will be showing the 1st position and the percentage open for the vent. Use the **VALUE** switch to raise or lower the flashing value. Entering a value greater than 95 percent open will assume that no more stages in vent opening are to be entered. Depress the **SET** switch to adjust the next stage of opening. Continue until all desired stages, up to eight, are entered.

### To Set the Vent Override Position.

1. (If Vent Override Input is not used, this instruction will not apply) Continue to depress the **SET** switch until the display shows **Or OP** on the display. The display will be flashing the maximum allowed position of the vent during an override. Use the **VALUE** switch to raise or lower the flashing value.

### To Set the Clock:

1. Continue to depress the **SET** switch until the **SET TIME** indicator is on. The item to be set will be flashing. Use the **VALUE** switch to raise or lower the flashing value. The first value will be hours. Depress the **SET** switch again to set the minutes, and once more to set if it is AM or PM.

### To Set the Day and Night Mode Times:

The control can detect night automatically with the use of an external photocell. If no photocell is connected, it will use the internal 24 hour time clock. You can also use a combination of both if desired.

1. Continue to depress the **SET** switch until the **SET DAY MODE** indicator is on. If a photocell is connected to the system, adjust the hours setting till the word "**PHO**" appears in the display. If a photocell is not connected, a time can be set. Use the **VALUE** switch to change the setting.

2. Depress the **SET** switch again and repeat the above procedure to **SET NIGHT MODE**. If you do not want the NIGHT mode to be used, adjust the hours setting until "**OFF**" appears in the display.

### To Activate the DIF Mode

The Growstat has a built in DIF mode of operation. The DIF mode is used to control plant growth based on a temperature differential between the day and night modes. The Growstat allows the user to set a special time for this mode. For truly automatic operation, a photocell should be used to automatically detect the actual sunrise time.

### To set the DIF time period:

1. Continue to depress the **SET** switch while the **SET TIME** indicator is on while the **DIF** indicator is also lit. the word "**OFF**" will be shown. This means that the DIF mode is disabled. By toggling the **VALUE** switch, a number proceeded by a negative sign will be shown (**-8.0** example). This will be the number of hours before sunrise, or before the set day mode time that the Growstat will use to enter the DIF mode. Set any value in .5 hour increments desired. After this negative number is set, depress the **SET** switch again. A number will appear without a negative sign in front of it (**2.0** example). This will be number of hours after sunrise or after the set day mode that the Growstat will use to exit the DIF mode.

2. Return to the run mode by toggling the **RUN** switch up.

### To Calibrate the Control:

The control can be calibrated easily. Calibration is best performed in the early or late hours to prevent the interaction of the solar influence. Using a good mercury or digital thermometer and hydrometer, obtain the value to calibrate the control to.

1. Continue to depress the **SET** switch until the **CALIB** is on the display. The first number to appear afterwards is the temperature. Use the **VALUE** switch to change the setting.
2. Depress the **SET** switch again and repeat the above procedure to set the humidity reading. Return to the run mode when finished.

OUTPUT NOTE:  
 THE CONTROL OUTPUTS  
 ARE RATED AT 1 AMP @ 24  
 VAC EACH MAXIMUM. DO  
 NOT EXCEED THIS OR  
 DAMAGE MAY RESULT. DO  
 NOT EXCEED 1 AMP @ 24  
 VAC FOR ANY SINGLE  
 OUTPUT.

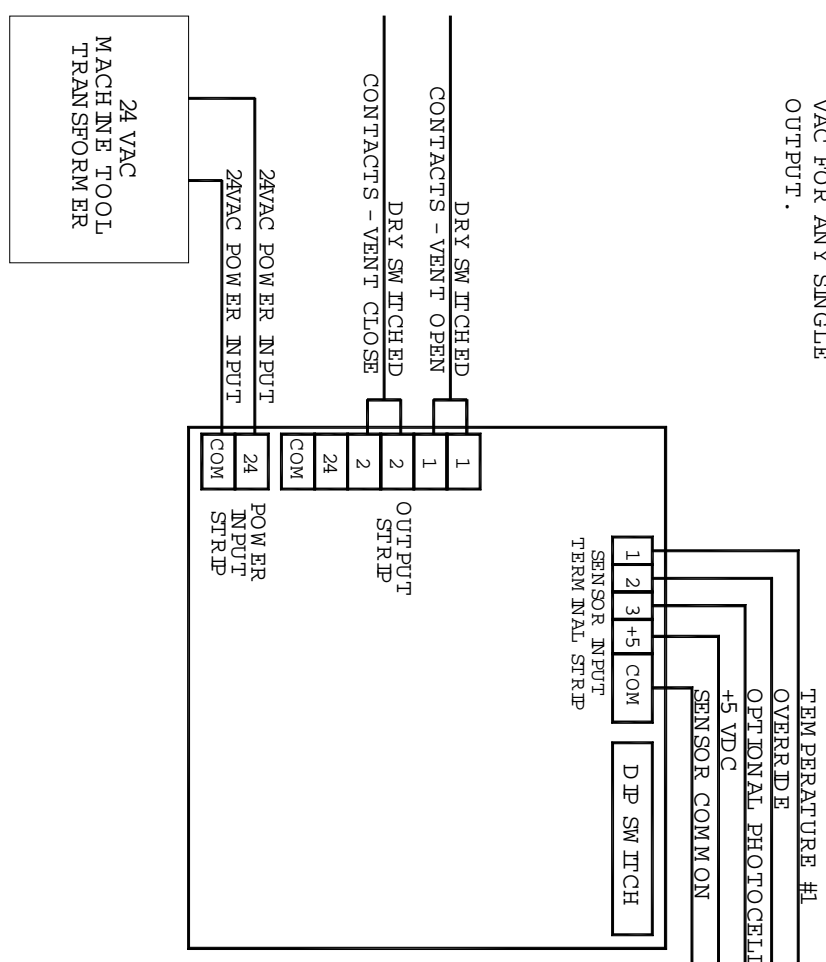

### DIP SW ITCH SETTINGS

TEMPERATURE MODE	TEMPERATURE #1	TEMPERATURE #2	TEMPERATURE #3	TEMPERATURE #4	TEMPERATURE #5	TEMPERATURE #6	TEMPERATURE #7	TEMPERATURE #8	TEMPERATURE #9	TEMPERATURE #10	TEMPERATURE #11	TEMPERATURE #12
FAHRENHEIT	PHOTOCELL	PHOTOCELL IN USE	DIFFERENTIAL	1 DEGREE	2 DEGREES	3 DEGREES	4 DEGREES	DIP NOT IN USE	MAXIMUM POSITION ALLOWED	2 SECONDS	30 SECONDS	60 SECONDS
CENTIGRADE	NO PHOTOCELL	NO PHOTOCELL	NO PHOTOCELL	NO PHOTOCELL	NO PHOTOCELL	NO PHOTOCELL	NO PHOTOCELL	DIP IN USE	GOTO THAT POSITION	6 SECONDS	10 SECONDS	120 SECONDS
PHOTOCELL	PHOTOCELL IN USE	NO PHOTOCELL	DIFFERENTIAL	1 DEGREE	2 DEGREES	3 DEGREES	4 DEGREES	DIP NOT IN USE	MAXIMUM POSITION ALLOWED	2 SECONDS	30 SECONDS	60 SECONDS
PHOTOCELL IN USE	NO PHOTOCELL	NO PHOTOCELL	DIFFERENTIAL	1 DEGREE	2 DEGREES	3 DEGREES	4 DEGREES	DIP IN USE	GOTO THAT POSITION	6 SECONDS	10 SECONDS	120 SECONDS
NO PHOTOCELL	NO PHOTOCELL	NO PHOTOCELL	DIFFERENTIAL	1 DEGREE	2 DEGREES	3 DEGREES	4 DEGREES	DIP NOT IN USE	MAXIMUM POSITION ALLOWED	2 SECONDS	30 SECONDS	60 SECONDS
NO PHOTOCELL	NO PHOTOCELL	NO PHOTOCELL	DIFFERENTIAL	1 DEGREE	2 DEGREES	3 DEGREES	4 DEGREES	DIP IN USE	GOTO THAT POSITION	6 SECONDS	10 SECONDS	120 SECONDS

## VENTSTAT INPUTS AND OUTPUTS

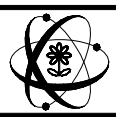

MICRO GROW GREENHOUSE SYSTEMS, INC.  
 26111 Ynez Road, Suite C-4  
 Temecula, CA 92591  
 Phone 909.296.3340 Fax 909.296.3350

Project		VENTSTAT INPUT AND OUTPUTS	
Drawn by	Date	Distributor	Order#
GH	11/13/01	N/A	N/A



### OPTIONAL PHOTOCELL

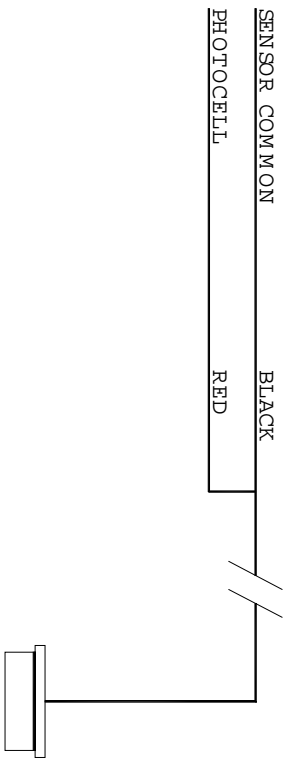

### VERRIDE

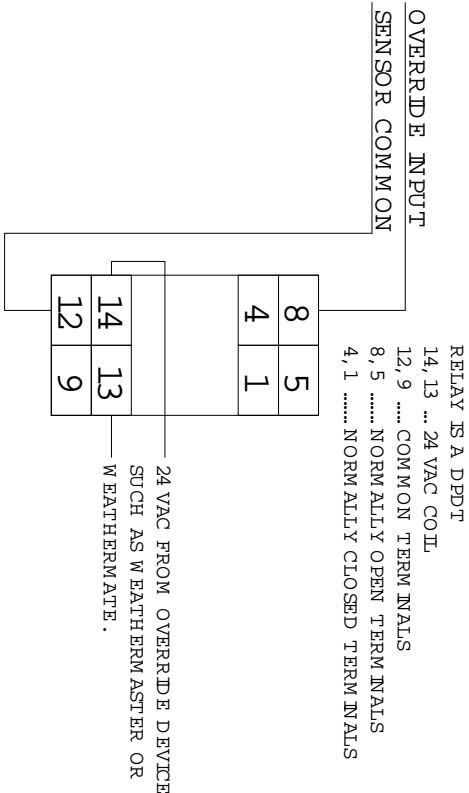

### TEMPERATURE SENSOR

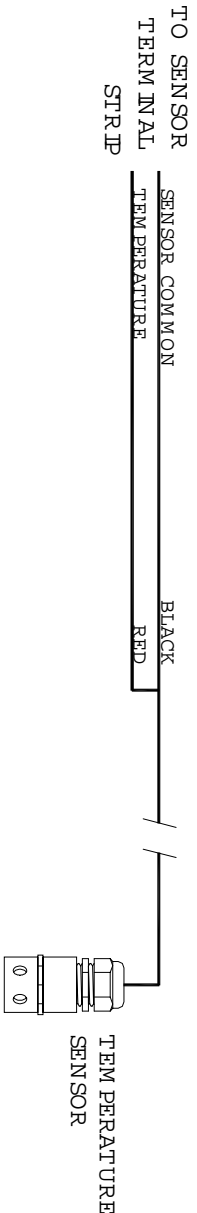

LOCATE SENSOR IN THE CENTER OF THE CONTROLLED AREA, AT BENCH OR CROP LEVEL, AWAY FROM DIRECT CONTACT WITH GREENHOUSE METAL POSTS AND MEMBERS.

### VENT STAT SENSORS



M C R O G R O W GREENHOUSE SYSTEMS, INC .  
 26111 Ynez Road, Suite C-4  
 Temecula, CA 92591  
 Phone 909.296.3340 Fax 909.296.3350

Project				VEN T STAT SENSORS			
Drawn by	Date	Distributor	Order D	Drawn by	Date	Distributor	Order D
GH	11/13/01	N/A	N/A	GH	11/13/01	N/A	N/A

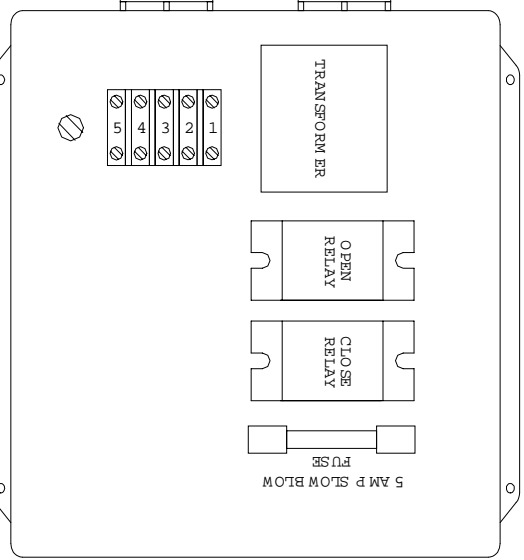
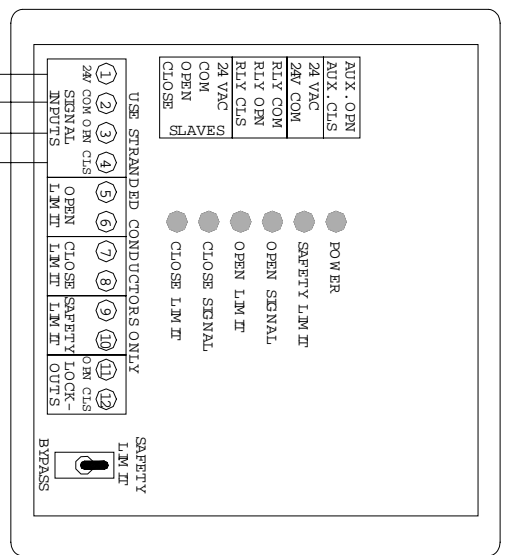

**SERIES 100 MASTER**

**OUTPUT NOTE:  
THE CONTROL  
OUTPUTS ARE RATED  
AT 1 AMP EACH**

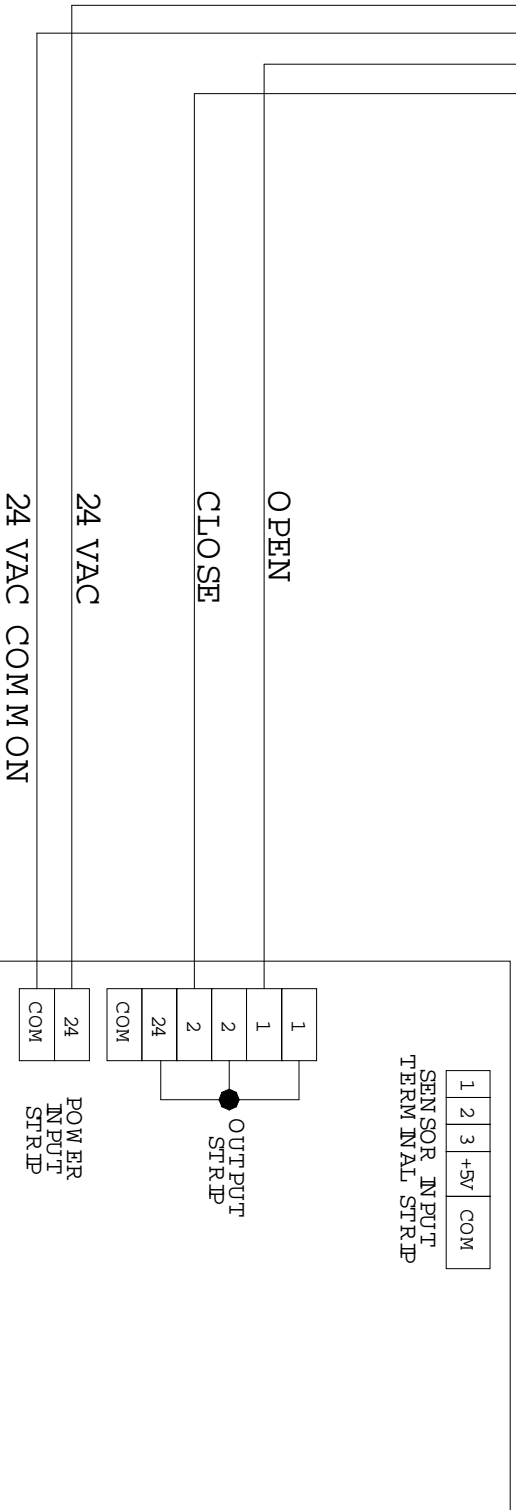

**VENTSTAT**

**VENTSTAT CONNECTION TO  
SERIES 100 MASTER**



**M I R O G R O W GREENHOUSE SYSTEMS, INC.**  
26111 Ynez Road, Suite C-4  
Temecula, CA 92591  
Phone 909.296.3340 Fax 909.296.3350

Project <b>VENTSTAT CONNECTION TO SERIES 100 MASTER</b>			
Drawn by GH	Date 11/05/01	Distributor N/A	Order ID N/A

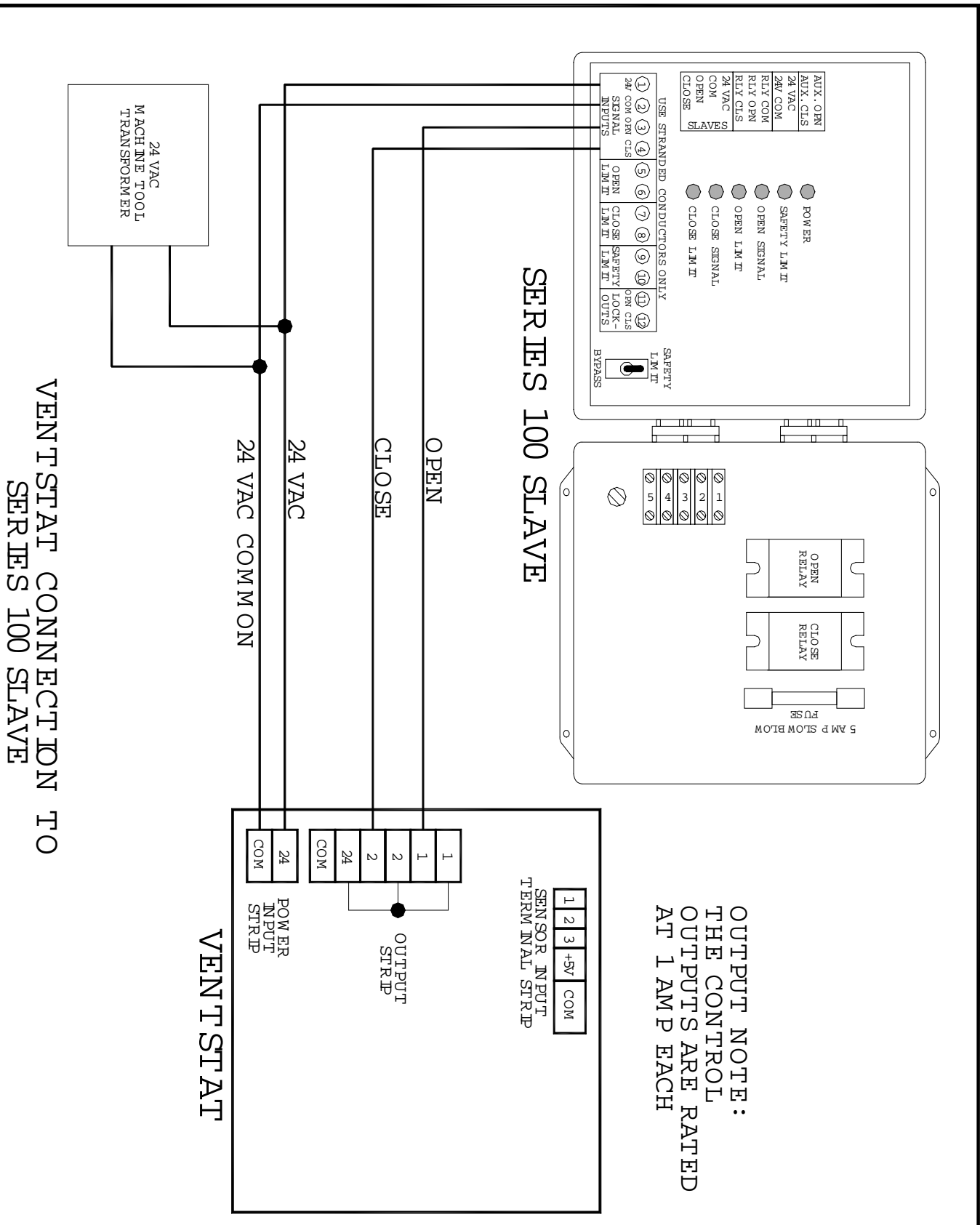

VENTSTAT CONNECTION TO SERIES 100 SLAVE

OUTPUT NOTE:  
THE CONTROL  
OUTPUTS ARE RATED  
AT 1 AMP EACH



MICRO GROW GREENHOUSE SYSTEMS, INC.  
26111 Ynez Road, Suite C-4  
Temecula, CA 92591  
Phone 909.296.3340 Fax 909.296.3350

Project		VENTSTAT CONNECTION TO SERIES 100 SLAVE		
Drawn by	Date	Distributor	Order ID	
GH	11/05/01	N/A	N/A	

WADSWORTH 2R  
VENT CONTROL SYSTEM

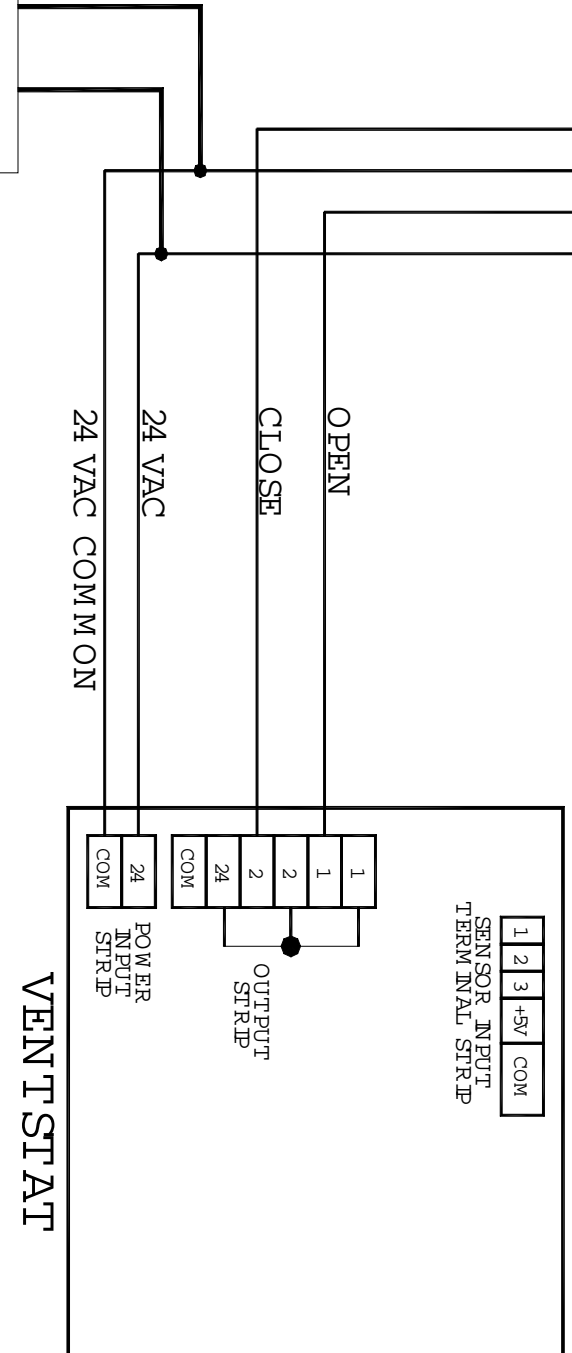
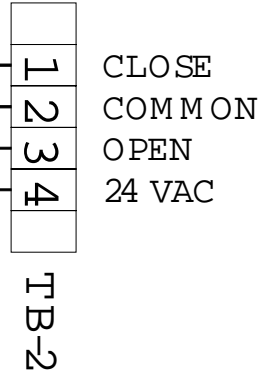

OUTPUT NOTE:  
THE CONTROL  
OUTPUTS ARE RATED  
AT 1 AMP EACH

VENTSTAT CONNECTION TO  
WADSWORTH 2000-2R & WADSWORTH 100-2R

WADSWORTH 2000-I  
WADSWORTH 100-I  
VENT CONTROL SYSTEM

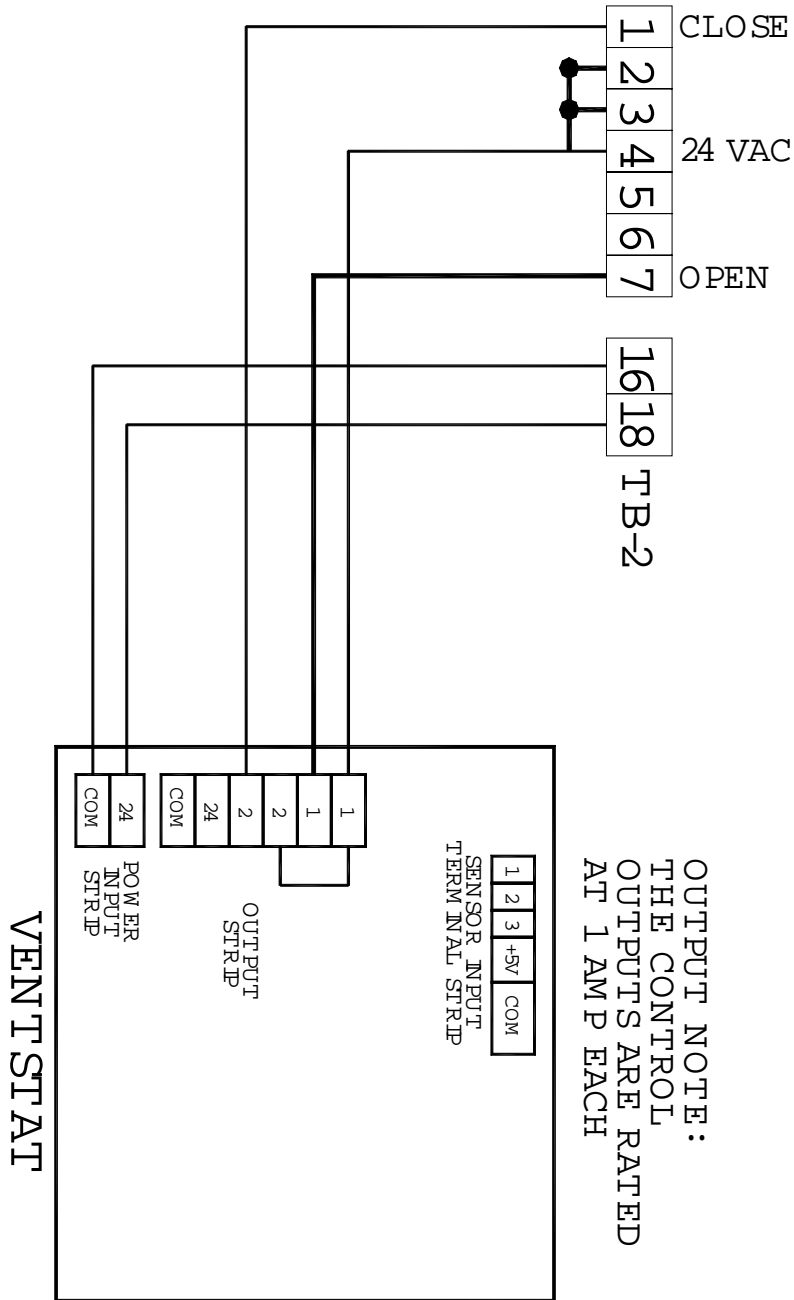

OUTPUT NOTE:  
THE CONTROL  
OUTPUTS ARE RATED  
AT 1 AMP EACH

VENTSTAT CONNECTION TO  
WADSWORTH 2000-I & WADSWORTH 100-I



MICRO GROW GREENHOUSE SYSTEMS, INC.  
26111 Ynez Road, Suite C-4  
Temecula, CA 92591  
Phone 909.296.3340 Fax 909.296.3350

Project VENTSTAT CONNECTION TO WADSWORTH-I

Drawn by GH	Date 11/13/01	Distributor N/A	Order ID N/A
----------------	------------------	--------------------	-----------------

WADSWORTH LST  
VENT CONTROL SYSTEM

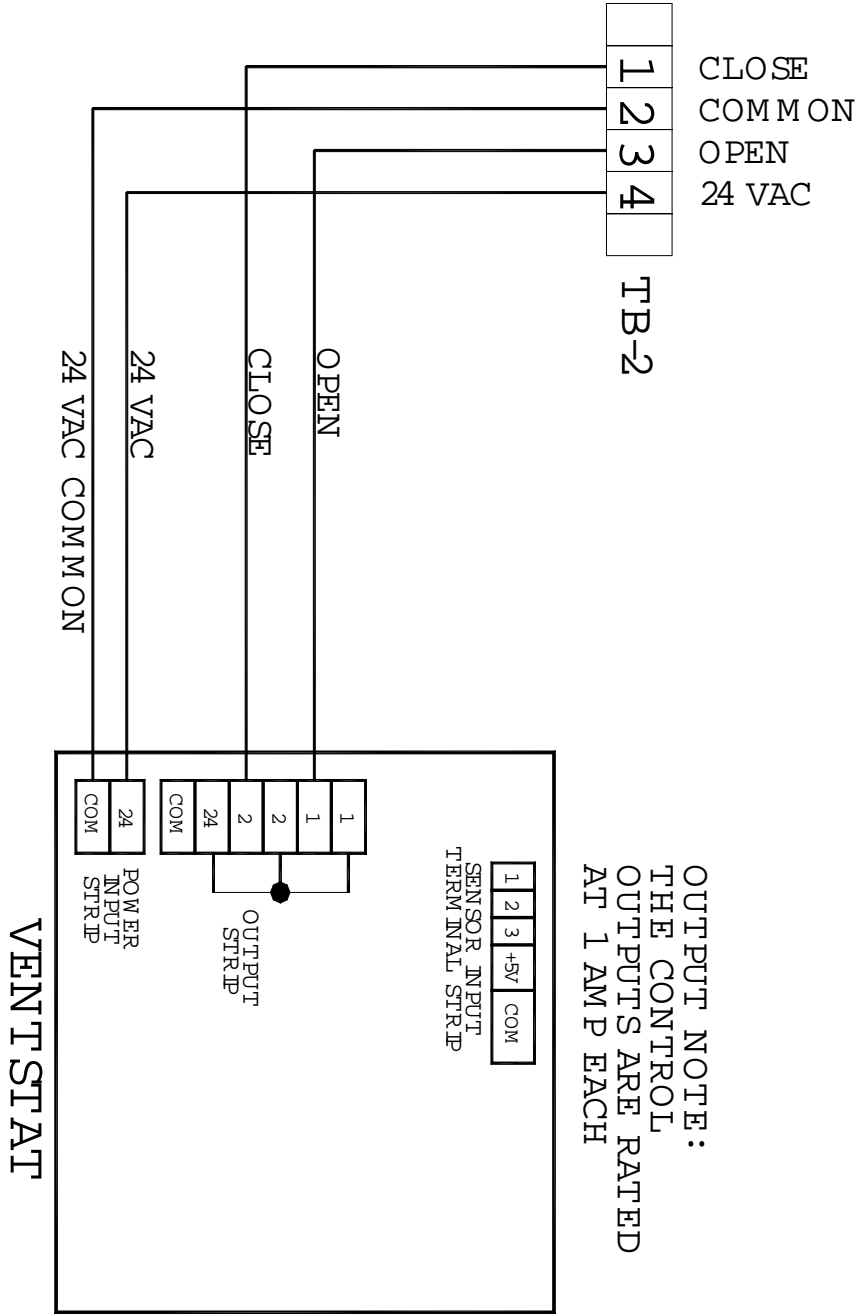

VENTSTAT CONNECTION TO  
WADSWORTH 2000-LST & WADSWORTH 100-LST



MICRO GROW GREENHOUSE SYSTEMS, INC.  
26111 Ynez Road, Suite C-4  
Temecula, CA 92591  
Phone 909.296.3340 Fax 909.296.3350

Project VENTSTAT CONNECTION TO WADSWORTH LST

Drawn by GH	Date 11/13/01	Distributor N/A	Order ID N/A
----------------	------------------	--------------------	-----------------

## LIMITED WARRANTY

Micro Grow Greenhouse Systems, Inc. warrants that all of the products Micro Grow Greenhouse Systems, Inc. manufactures are free from defects at the time of shipment by Micro Grow Greenhouse Systems, Inc. This warranty covers defects in workmanship and materials. No warranty is extended on any parts, materials, or components manufactured by others and purchased by Micro Grow Greenhouse Systems, Inc., and any warranty on these materials is limited to the warranty supplied by the original manufacturer or supplier of said products only. This warranty excludes any and all damages cause by installation by unqualified individuals, damage by misuse or neglect, shipment damage, alterations to original manufacturing, and improper installation or use for any reason than intended by manufacturer. This warranty may not be altered in any manner except with the written authorization of one the officers or owners of Micro Grow Greenhouse Systems, Inc. The only and sole liability of Micro Grow Greenhouse Systems, Inc. under this warranty is limited to repairing, replacing or the issuance of credit for any products returned to Micro Grow Greenhouse Systems, Inc., during the warranty period of twelve (12) months from date of shipment. This warranty is specifically conditioned upon Micro Grow Greenhouse Systems, Inc. being notified in writing promptly upon discovery of any product defects by the buyer or end user. The product must then be returned prepaid to Micro Grow Greenhouse Systems, Inc. within the twelve month warranty period for inspection by Micro Grow Greenhouse Systems, Inc. Upon inspection of said product, Micro Grow Greenhouse Systems, Inc. will notify buyer or end user of its findings. At Micro Grow Greenhouse Systems, Inc. sole discretion, the product will be replaced, repaired or a credit will be issued for the original sale price of the product, provided that damage has not occurred due to misuse, neglect, improper use or installation as outlined above, shipping damages or accident.

**MICRO GROW GREENHOUSE SYSTEMS, INC. SHALL NOT BE LIABLE FOR ANY DAMAGES BEYOND THE ACTUAL ORIGINAL COST OF THEIR PRODUCT EITHER DIRECTLY OR INDIRECTLY ARISING FROM DEFECTIVE PRODUCTS OR WORKMANSHIP.**