



Trac-Rite[®]

Door, Inc.

ROLLING CURTAIN DOOR INSTALLATION, MAINTENANCE & PARTS MANUAL

MODEL 955



WARNING

Read manual prior to installing door. Overhead doors are large, heavy objects that move with the help of springs under extreme tension. Since moving objects and springs under tension can cause injuries, your safety and the safety of others depends on you reading and following the information in this manual. Re-check your work prior to operating door.

| POTENTIAL HAZARD | EFFECT | PREVENTION |
|-------------------------------|-----------------------------------|--|
| MOVING DOOR | Can Cause Serious Injury or Death | Keep people clear of opening while door is moving. Get help or use support when lifting new door into place. |
| EXTREME SPRING TENSION | Can Cause Serious Injury or Death | Installation, repairs, and adjustments must be made by a qualified door mechanic using proper tools, methods and instructions. Before winding torsion spring, make sure door is fully open and curtain is wrapped on barrel. |

NOTE!

DO NOT CUT BANDS which hold door in a roll. You will be told at a later time exactly when to cut bands. No guarantee will be given or responsibility accepted by Trac-Rite Door if door is not installed as instructed. For proper operation, follow instructions given.



CAUTION

Use proper lifting equipment and correct lifting procedures to avoid injury.

216 Wilburn Road, Sun Prairie, WI 53590
Phone: 800-448-8979; Fax: 800-236-8722
Technical Help Line: 888-700-TRAC (8722)
Web Site: www.tracrite.com
E-mail: tr@tracrite.com

This Manual **MUST** Be Left with the Owner.

Door Assembly - Parts Layout

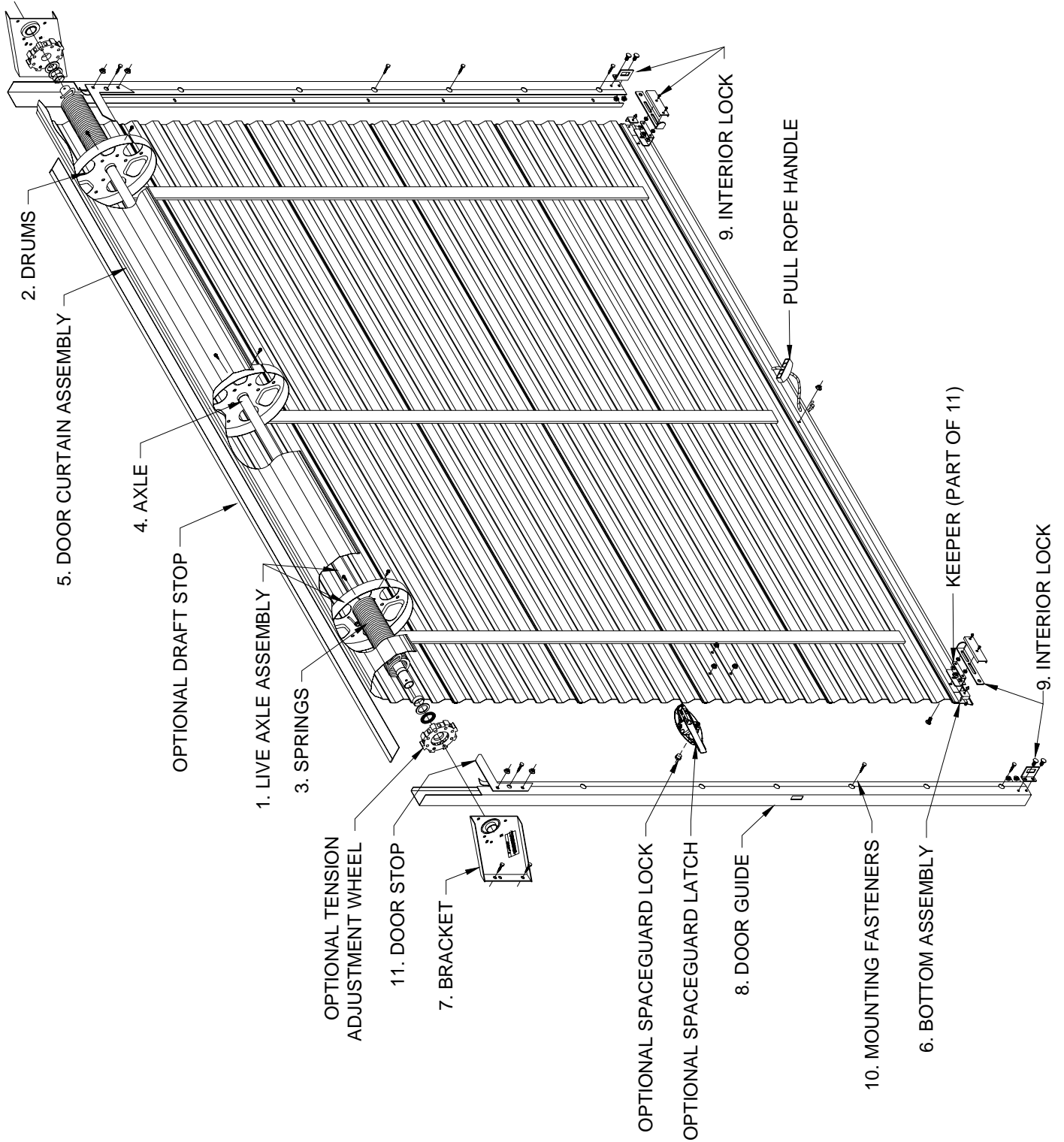



WARNING

Improper installation of anchoring devices or installation into aged or unsound concrete block, or other wall material may result in premature product wear, product failure, property damage or serious personal injury.

Prior to beginning door installation, thoroughly read the instruction manual in its entirety. Please contact Trac-Rite with any questions at 888-700-8722. Answering questions up front will greatly reduce installation miscues.

1. GENERAL:

In this document, the following terms are defined as:

Warning - serious personal injury or death can result from failure to follow instructions.

Caution - minor injury or property damage can result from failure to follow instructions.

Note - special attention should be given to the instructions.

NOTE!

Do not install this rolling steel curtain door unless you read and understand the installation instructions!

- Do not cut the bands which hold the door curtain in a roll! This is performed once the door has been hung in the opening.

- Once the door has been installed, on the inside of the door curtain, you will find full door height strips of white felt tape. **Do not remove!** It is not packaging material.

2. INSPECTION:

2.1 Door and Hardware: Upon receiving the door shipment, immediately inspect the door and hardware for damage. Verify the product received with the packing list. Damages and/or shortages should be reported immediately to Trac-Rite Customer Service at 800-448-8979. Please have your

bill of lading and packing list with you when reporting shortages or damage. Do not install damaged material without authorization from Trac-Rite.

2.2 Door Width Verification: The door curtain width should measure 5" greater than the framed opening width.

2.3 Framed Opening Verification:

- Proper size dimensionally?
- Opening square? Plumb?
- Is the jamb structurally/dimensionally adequate? Reference paragraph 3. Jamb Preparations for specifics.
- Clearances? (Reference Figure 1)

3. JAMB PREPARATION:

3.1 Are the jambs structurally and/or dimensionally adequate to accept door brackets and guides? **Trac-Rite is not responsible for the structural integrity of the jamb itself!**

3.2 Narrow Jamb Application: Narrow jamb plates are available, from Trac-Rite, for situations in which the jamb alone is not wide enough to mount the bracket to. Ideally this condition should be made known at the time of order entry so that you will have the hardware when you need it.

Note that narrow jamb plates are not designed to strengthen the jamb! Used in combination with proper structural support, they will aid in locating the door brackets properly.

3.3 **Trac-Rite does not supply fasteners** for attaching the door brackets and guides to concrete or concrete masonry jambs. Trac-Rite only supplies fasteners for metal and wood jambs.

| RECOMMENDED INSTALLATION CLEARANCES | | | | | | |
|-------------------------------------|-----|-----|---------------------|--------------|---------------------|------------------------|
| OPENING HEIGHT | A * | B * | C WOOD/ STEEL | C MASONRY | C CHAIN HOIST | C MOTOR OPERATOR |
| UP TO 9'-5" | 19" | 21" | 5" | 7" | 9" | 21.5" |
| 9'-6" - 14'-2" | 20" | 22" | 5" | 7" | 9" | 21.5" |

* ADD 1" TO A AND B FOR INSULATED DOORS.

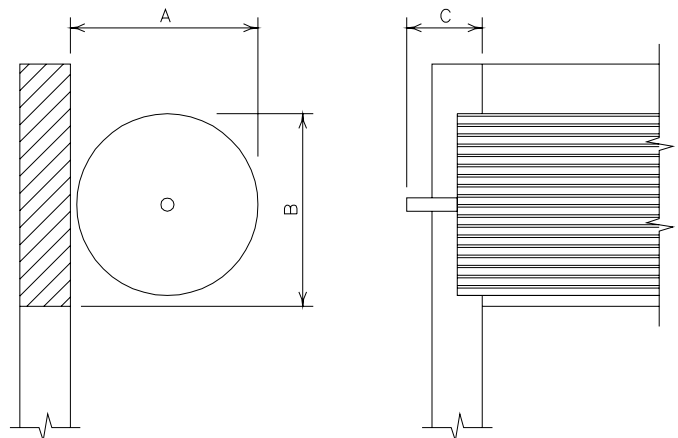

Figure 1



WARNING

Do not use model 944 hardware on model 955 doors. It is not structurally adequate. If door falls, serious injury and/or damage to door can result.

- Door bracket to jamb fasteners must be 3/8" in diameter, and be constructed of ASTM A-307 steel or greater.
- Door guide to jamb fasteners must be 1/4" in diameter, and be constructed of ASTM A-307 steel or greater.

3.4 Pre-drill jambs to accept door brackets; 7/16" diameter holes for 3/8" nuts and bolts in steel jambs, proper size pilot hole for 3/8" lag bolt in wood jambs. Hole locations are shown in Figure 2. Do not pre-drill jambs for door guide installation. NOTE: Door must be hung level to insure proper tracking.

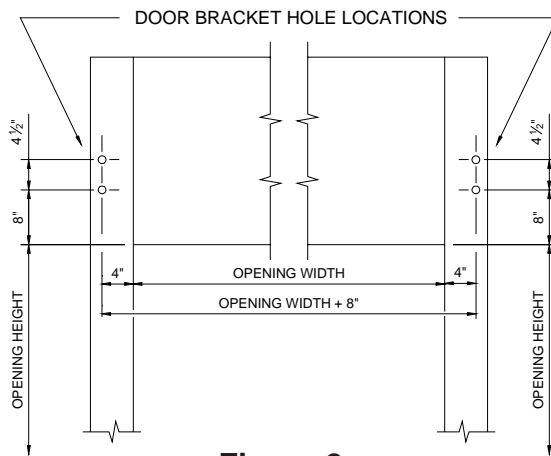

Figure 2.



WARNING

Do not install or use a Tension Adjustment System on doors over 12'8" tall. Tension could release, allowing door to fall. Serious personal injuries and/or damage to the door could result.

NOTE!

Steps for the optional Tension Adjustment System are noted with a "T" following the step number.

SKIP 4.T AND 4.1T IF TENSION ADJUSTMENT SYSTEM WAS NOT PURCHASED. PROCEED TO STEP 5.

4.T TENSION BRACKET ASSEMBLY:

On small doors (with only one spring) the tension adjustment system is installed on the left bracket as shown. On doors with two springs, the system is installed on both sides.

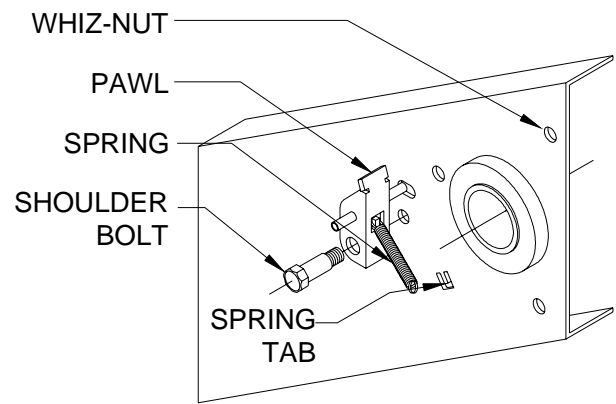

Figure 3.

4.1T Attach the small spring to tabs on the tension release pawl and the inside of door bracket. Then stretch the spring until the holes are lined up and secure with 3/8" shoulder bolt and 5/16" whiz nut. See Figure 3. Repeat on other bracket.

5. BRACKET AND GUIDE ASSEMBLY:

5.1 Position the door in the opening as shown in Figure 4. Be sure to place the door on a protective material to prevent damage to the curtain.

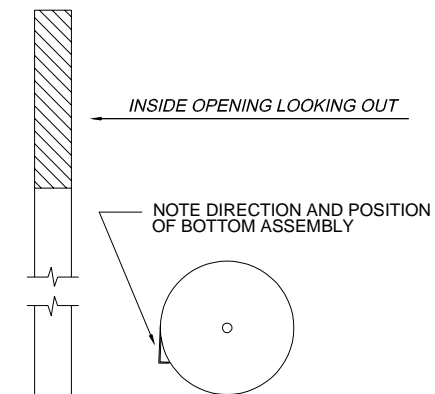

Figure 4.

SKIP 5.2T IF TENSION ADJUSTMENT SYSTEM WAS NOT PURCHASED. PROCEED TO STEP 5.3.

5.2T Slide the steel washer onto the axle, then the black nylon washer. See Figure 5. Apply a small amount of grease to the black nylon washer to assure smooth operation. Stretch spring past axle end and slide door bracket between coils and end of axle. This makes it easy to get the bolt started. Pass a 5/16" bolt with a flat washer through the loop in the end of the door spring and screw into tapped hole in the tension adjustment wheel. Slide the tension adjustment wheel onto axle. ENSURE THAT THE SPRING FITS AROUND THE RING ON THE TENSION WHEEL BEFORE FINAL TIGHTENING. See Figure 6. Slip the axle end through the bearing in the door bracket. Rotate the tension release pawl to allow the tension adjustment wheel to slide pass. Install the second steel washer onto the axle and secure with a cotter pin through the hole punched in the axle end to keep the door bracket in place (omit washer if it blocks cotter pin hole). Repeat on other end if the door has two springs.

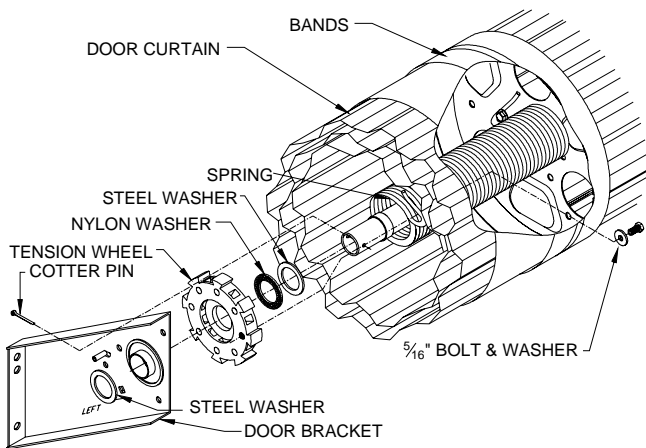

Figure 5.

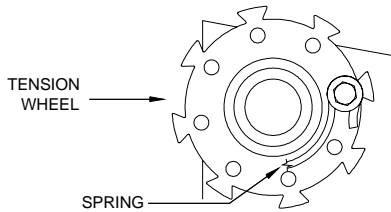
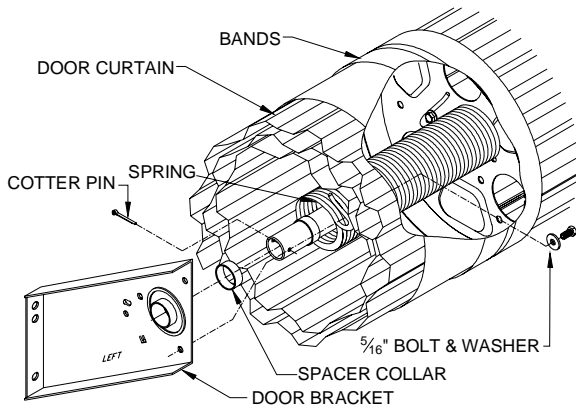

Figure 6.

5.3 The next two steps are for doors without the optional tension adjustment system and for the opposite side on doors with a single system (single spring doors).

5.4 Slide the spacer collar onto the axle (collar NOT used on doors greater than 12'-8" tall) then slip the axle ends through the bearings in the door brackets. Install a cotter pin through the hole punched in each axle end to keep the door brackets in place. See Figure 7.



NOTE: OMIT SPACER COLLAR ON DOORS OVER 12'-8" TALL

Figure 7.

5.5 Position bracket in rough alignment with the bottom assembly. See Figure 8 Ensure that the door spring is in a relaxed position. Pass a 5/16" bolt with a flat washer through the loop in the end of the door spring and through the nearest of three holes in the door bracket. Secure with a 5/16" whiz nut. Repeat on the other end if the door comes with two springs. ENSURE THAT THE SPRING FITS AROUND THE BEARING IN THE BRACKET BEFORE FINAL TIGHTENING. See Figure 9.

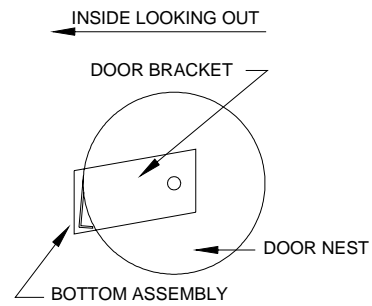

Figure 8.

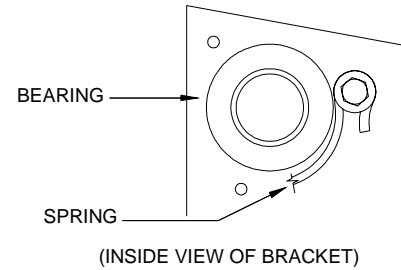

Figure 9.

6. HOIST DOOR INTO OPENING:

WARNING

Do NOT allow personnel to ride on forklift or other hoisting equipment being used to lift the curtain assembly into position. Do not permit any persons to climb on ladders near the curtain assembly while it is being hoisted. Should the curtain assembly slip it can cause **SERIOUS INJURY or **DEATH** to persons standing on ladders or riding on lifting equipment.**

6.1 Utilizing whatever method currently available (fork lift, block and tackle, etc.), hoist the door up into the header section of the opening and fasten the door brackets to the jambs using the pre-drilled holes and fasteners described in section 3. Jamb Preparation.

7. GUIDE POSITIONING:

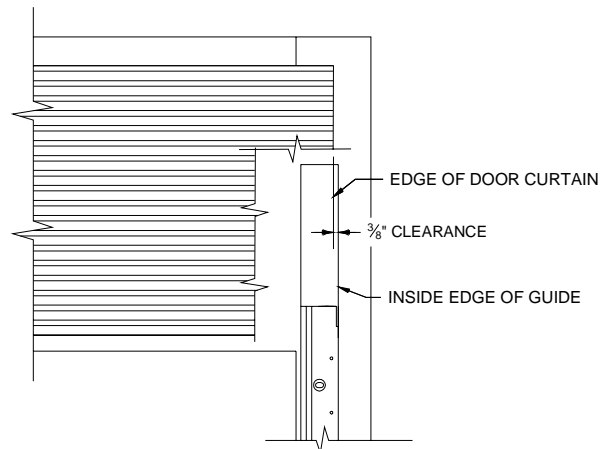

Figure 10.

7.1 Position the guides against the jambs according to the clearance shown in Figure 10. Loosely fasten the guides to the jambs using a fastener in the top hole only. Guides will need slight adjustment therefore **DO NOT** install the balance of the fasteners until such time as the adjustment is true. Level one guide, and loosely install a second fastener in the bottom hole. If mounting to masonry, install clips provided as shown in Figure 11. Align the clips with the holes along the length of the guide and flush with the back of the guide. (Anchors by others).

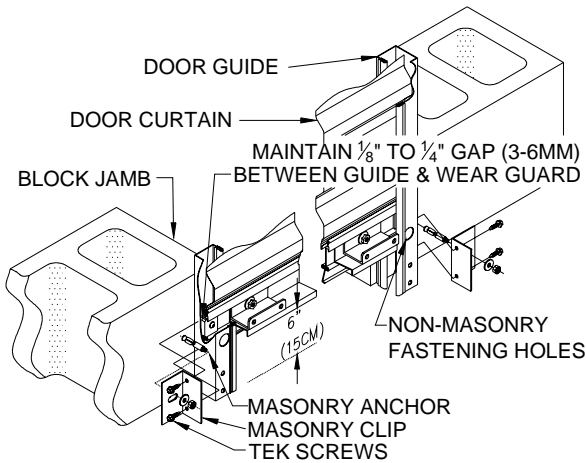

Figure 11.

8. PRE-TENSIONING & TOP STOP ASSEMBLY:

8.1 Install the track bolts, door stops and whiz nuts in each side guide as shown in Figure 12. Do not tighten at this time.

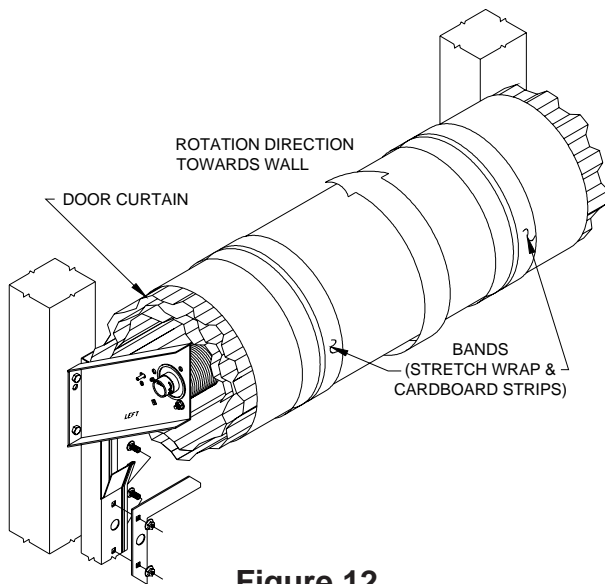

Figure 12.

8.2 Bend the guide tabs out slightly (about 1/4"). Standing inside the opening looking out, place your hand on top of the door and push away from you rotating the door nest. (Figure 12) For doors 6'-1" tall or shorter with one spring rotate the door nest 3 2/3 to 4 revolutions. For doors taller than 6'-1" rotate the door nest 2 complete revolutions. (Note: if the door is equipped with a chain hoist, it can be quite helpful in door pre-tensioning. Please reference section 10

Operators). Hanging on to the door bottom assembly, carefully cut the steel bands and feed the door curtain into the guides, pulling it down to about waist level. Move door stop aside, to let bottom bar move past.

CAUTION

Care must be taken that the door does not spin around free as this may cause personal injuries and damage door curtain. **DO NOT** grab the springs or unbolt the springs while there is any tension on the door as this may cause personal injuries.

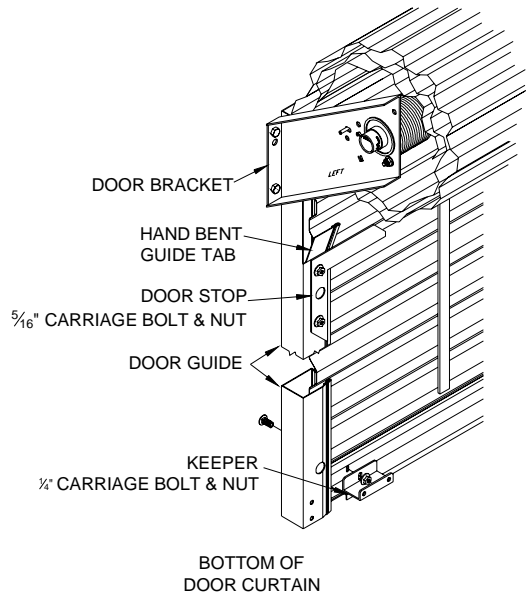

Figure 13.

WARNING

Immediately install keepers and door stops. These devices will prevent the door from rolling up and out of the guides.

8.3 Attach the two keepers to the bottom interior edge of the door with one (1) 1/4" carriage bolt and whiz nut in each keeper. See Figure 13.

8.4 Tighten door stops installed in paragraph 8.1 making certain track bolts are seated in guides. (Figure 13)

NOTE!

Check the balance of the first door installed after Step 11, before installing all the doors this size. This will reduce a great deal of potential rework later.

9. GUIDE ADJUSTMENT:

9.1 With the door approximately 6" from the floor, adjust the guides so if you grab the door by its bottom assembly, you shall be able to move it laterally approximately 1/4". Once the guides are adjusted properly, install the balance of fasteners and firmly tighten them.

9.2 Attach guide warning label (shown in Figure 14) to the guide at eye level.

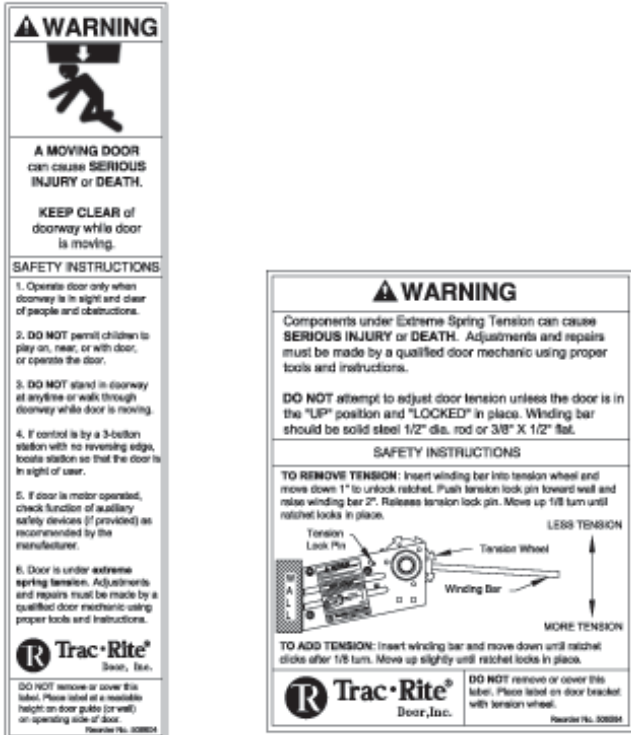

Figure 14.

9.3T If tension adjustment system was installed, attach tension adjustment warning label (shown in Figure 14) either on the door bracket with the tension wheel or to wall at eye level.

10. INTERIOR LOCK INSTALLATION:

10.1 Position door at waist level.

10.2 Assemble components as shown in Figure 15, noting that two (2) high collar lock washers are placed over each 1/4" one-way screw to allow the lockbar to slide freely.

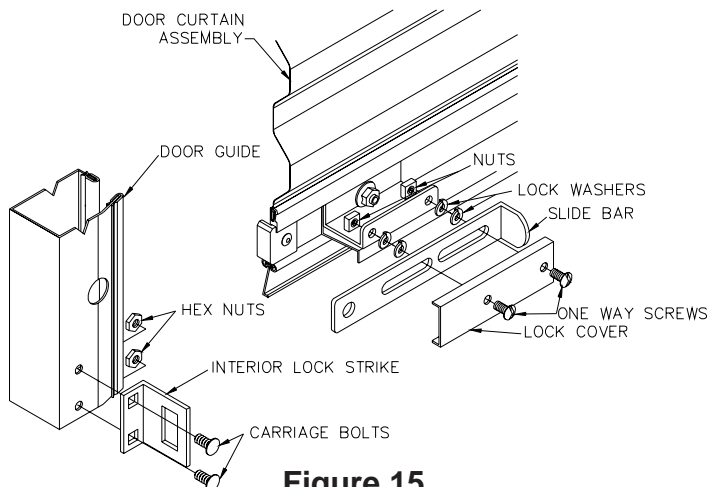

Figure 15.

10.3 As the 1/4" screws are being tightened, move the lockbar to assure that the high collar lock washers are inside the slots in the lockbar.

10.4 Mount the lock strike to the bottom of each guide as shown with two (2) 1/4" carriage bolts and jam nuts through the pre-punched holes.

11. OPERATORS:

11.1 **Manual operation** -- Pull Rope Handle: Tie a knot in one end of the rope. Slide the plastic handle onto the rope and pull the knot up into the handle. Pass the other end of the rope through the hole in the center of the bottom edge of the door and tie another knot in the end to keep the rope from pulling through.

11.2 **Direct drive operator** -- direct drive chain hoists can be installed on either side of the door, prior to, or after the door is hung (although there may be clearance limitations). Please reference Figure 16 for specifics.

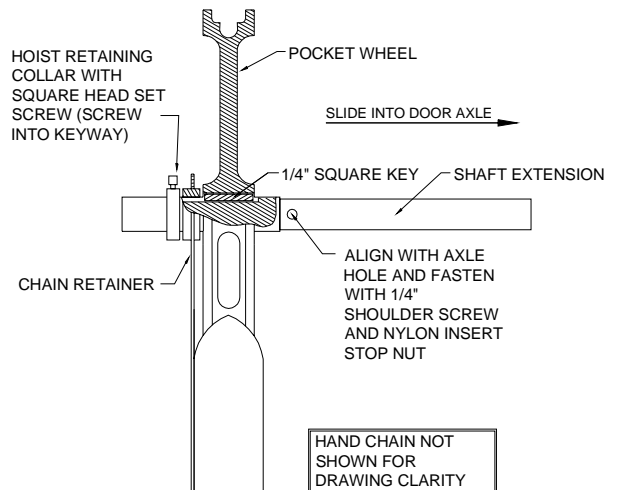

Figure 16.

11.3 **Reduced drive operator** — 4:1 chain hoist should be installed as shown in Figure 17.

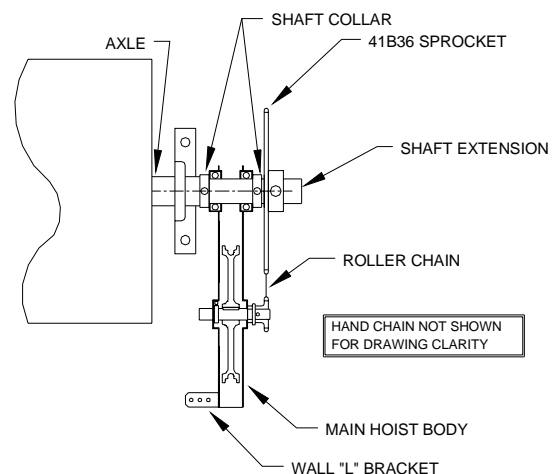

Figure 17.

11.3.1 Align hole in shaft extension with axle hole and fasten with 1/4" shoulder screw and nylon insert stop nut.

11.3.2 Assemble onto shaft extension as shown, making certain 41B36 sprocket is aligned with the sprocket on the hoist body and the 1/4" x 1/4" key is in place. Tighten all set screws.

11.3.3 Attach wall "L" bracket to main hoist body, to hold hoist level, and keep it from swinging during operation. Secure "L" bracket to wall.

11.3.4 Feed hand chain through and around pocketwheel. Shorten chain so that it does not lay on the floor, (1' to 3' off floor is fine). Close chain, making certain there are no twists in the chain.

11.3.5 Install roller chain around sprockets with connecting link provided.

11.3.6 Attach chain keeper clip to wall, (4' to 5' above floor).

12. ADJUSTING DOOR SPRING TENSION: SEE STEP 13T IF DOOR HAS OPTIONAL TENSION ADJUSTMENT SYSTEM(S).

12.1 To adjust door spring tension, first remove the door stops, keepers, and lift clip (if so equipped). Adjusting door spring tension is much easier with two people.



WARNING

Components under extreme spring tension can cause **SERIOUS INJURY** or **DEATH**. Adjustments and repairs must be made by a qualified door mechanic using proper tools and instructions. Remove all tension from door before unbolting spring(s). Care must be taken that the door does not spin around free, as this may cause personal injuries and damage to the door curtain.

12.2 Open the door but **DO NOT** allow it to come out of the guides. Strap two ropes **TIGHTLY** around the door curtain and tie the curtain **SECURELY** as it comes out of the guides.

12.3 Remove all turns (pre-tension) so that **NO** tension is on spring(s). Unbolt spring(s) from bracket(s).

12.4 Rotate top of curtain 1/3 turn toward wall to decrease tension, 1/3 turn away from wall to increase tension.

12.5 Reinstall bolt through the flat washer, spring, and bracket at hole in line with spring and tighten.

12.6 Reassemble, beginning with section 8. Make note of this adjustment so that any other doors of the same size can be tensioned the same as they are installed.

13.T OPTIONAL TENSION ADJUSTMENT SYSTEM USE:

13.1T Both sides of two spring doors should be adjusted to the same tension.



WARNING

Components under extreme spring tension can cause **SERIOUS INJURY** or **DEATH**. Adjustments and repairs must be made by a qualified door mechanic using proper tools and instructions. Do **NOT** attempt to adjust door tension unless the door is in the "UP" position and "LOCKED" in place. Winding bar should be solid steel 1/2" dia. rod or 3/8" X 1/2" flat

13.2T To remove tension, insert winding bar into tension wheel and move down 1" to unlock ratchet. Push tension lock pin toward wall and raise winding bar 2". Release tension lock pin. Move up 1/8 turn until ratchet locks in place.

13.3T to add tension, insert winding bar and move down until ratchet clicks after 1/8 turn. Move up slightly until ratchet locks in place. See Figure 18.

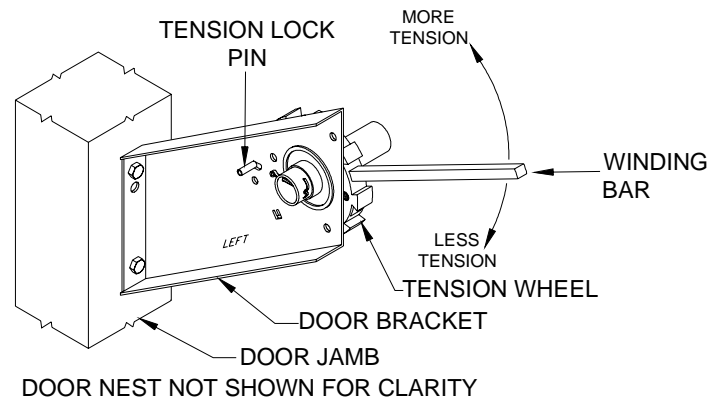

Figure 18.

14. OPTIONAL FIELD INSTALLED DRAFT STOP OR BRUSH SEAL:

14.1 Place the door in the closed position before installing the draft stop. Note that with the door down, the curtain may bow slightly near the top towards the inside; this bowing is normal. For the draft stop to be effective, it should follow the "bow" in the door curtain so that it stays in contact across the entire width of the door curtain. Starting at one end attach to header every 9 inches with appropriate fasteners, trim excess at other end if necessary.

14.2 Place the door in the closed position before installing the brush seal. Position brush seal so that it just touches the flat portion of the curtain. See Figure 19. Fasten brush seals to jamb every 12 inches with appropriate fasteners.

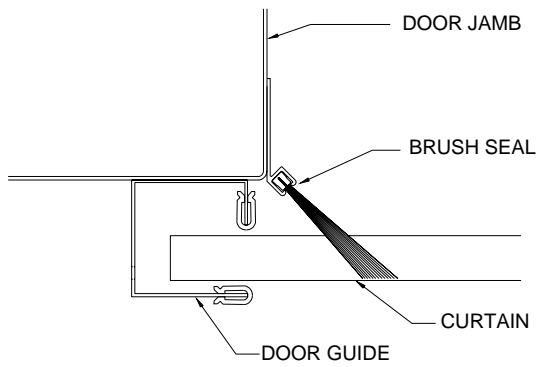

Figure 19.



CAUTION

Excessive force in operation may cause damage to the door.

15. MAINTENANCE

15.1 INSPECTION: Visually inspect the entire door monthly for general cleanliness and ease of operation.

15.1.1 Inspect the guides and curtain for wear and/or accidental damage.

15.1.2 Inspect all fasteners and anchor bolts for loose, damaged or missing parts.

15.1.3 If door is equipped with a chain hoist mechanism, inspect it for missing parts.

15.2 CLEANING: No specific cleaning procedures are required for your Trac-Rite Rolling Door. Clean as needed following good housekeeping practices.

15.2.1 Periodically clean any accumulated dirt from guides; remove any debris from the guide channels at the floor.

15.3 LUBRICATION: Lubricate the following every six months, or more often in dusty and/or wet operating environments.

15.3.1 Spring(s): Close the roll-up door so that the door springs are visible. With an oil pump can, pump a bead of oil across the length of each spring. Operate the door several times. The oil will work its way around the spring to help reduce friction and corrosion.

15.3.2 Guides: Open the door. Spray silicone spray, Pledge™, or Zep 45™ onto the door guide runners and inside the guide.

15.3.3 Lock: Spray the slide lock with silicone spray or Pledge™, to promote smooth lock operation.

15.3.4 Chain Hoist Parts: Apply a small amount of oil to roller chain.

16. SPRING REPLACEMENT:

NOTE!

Before you start: Read both this section and the complete Installation Manual to familiarize yourself with all of the components.

16.1 On doors with two springs, both should be replaced, even if only one spring is broken.

16.2 To replace a broken door spring, first remove the door stops, keepers, and exterior handle.



WARNING

Components under extreme spring tension can cause **SERIOUS INJURY** or **DEATH**. Adjustments and repairs must be made by a qualified door mechanic using proper tools and instructions. Remove all tension from door before unbolting spring(s). Care must be taken that the door does not spin around free, as this may cause personal injuries and damage to the door curtain.

16.3 Open the door but **DO NOT** allow it to come out of the guides. Strap two ropes **TIGHTLY** around the door curtain and tie the curtain **SECURELY** as it comes out of the guides. See Figure 20.

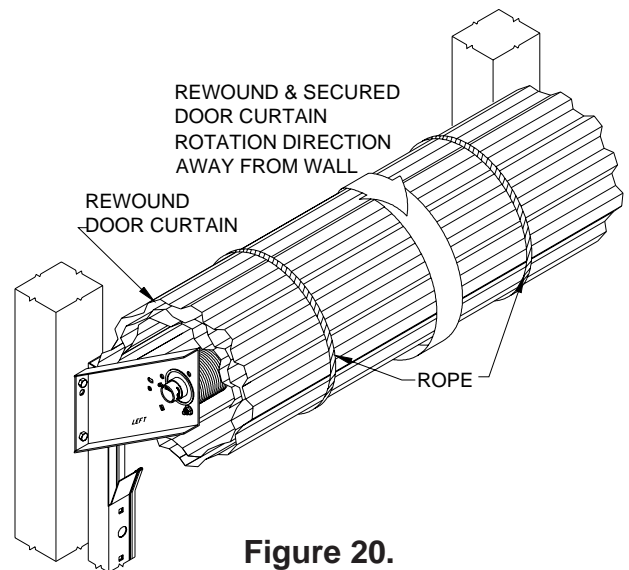

Figure 20.

16.4 Carefully rotate the door away from the wall until **NO** tension is on the spring(s). Unbolt spring(s) from bracket(s). On doors with optional tension adjustment system, reference Step 13.1T and Figure 18 to remove all tension on that side of the door.



CAUTION

Use proper lifting equipment and correct lifting procedures to avoid injury.

16.5 Unfasten the guides from the jambs. Save the fasteners for reinstallation later. Temporarily secure the door assembly in place with C-clamps or vise grips placed at the door brackets.

16.6 Unbolt both brackets, referencing Figure 9.

16.7 With one person holding up on each end of the door, or lifting equipment, remove the temporary clamping devices. Move the bottom of the guides out from the wall and carefully lower the curtain roll to the floor. **DO NOT LOWER THE DOOR BY THE GUIDES;** they will bend and become unusable!!

16.8 On the side of doors with the optional tension adjustment system, the spring is unbolted in step 16.14.

16.9 This step is for the opposite side of doors with a tension adjustment system and both sides of doors with none. Remove the 5/16" bolt and flat washer from the loop in the end of the door spring(s). Reference Figure 7.

16.10 Place some cardboard or other material on the floor where there is room to unroll the curtain.

16.11 Remove the cotter pin from the hole in each axle end that keeps the brackets in place. Remove bracket/guide assemblies and set aside. Reference Figures 5 and 7.

16.12 Place door roll at bottom edge of cardboard. While holding the door roll **SECURELY**, untie the ropes from around the door curtain. Slowly, unroll the curtain onto the cardboard.

16.13 Remove the 5/16" bolt and flat washer from the loop in the end of the door spring. Remove the old spring and replace with new spring. Reattach with the 5/16" bolt and flat washer through the loop in the spring and the door drum with 5/16" whiz nut. Repeat on the other end if the door comes with two springs. **NOTE:** Springs are color coded, red goes on the right, and blue goes on the left (viewing door from inside).

16.14 On doors with the optional tension adjustment system, remove the 5/16" bolt and flat washer from the tension wheel. Check that the black nylon and steel washers are installed correctly as shown in Figure 5. Replace tension wheel onto axle and bolt spring in place referencing Figure 6.

17.15 Slowly roll the curtain back up, then wrap two ropes **TIGHTLY** around the door curtain and tie the curtain **SECURELY**. Reinstall the door, following these Installation Instructions.

18. REPLACEMENT PARTS

Part No. Description

Locks:

521226 Interior Lock Package
601811 SpaceGuard Latch Package
502705 SpaceGuard Cam Lock
502721 Lock Out Key

Hardware:

603921 Bracket, Right Hand
603931 Bracket, Left Hand
502680 42" Rope (8' - 10' tall)
508840 72" Rope (10' - 12' tall)
508841 90" Rope (over 12' tall)
605000 Steel Jamb Package
605001 Wood Jamb Package
605002 Concrete Jamb Package
506586 Tension Wheel
506582 Winding Bar
506602 Tension Adjustment System Hdw. Pkg.

Springs:

600960 RH, 3.375" ID, 0.283 wire, 62 coils, 19.50"
600970 LH, 3.375" ID, 0.283 wire, 62 coils, 19.50"
600980 RH, 3.375" ID, 0.306 wire, 68 coils, 23.00"
600990 LH, 3.375" ID, 0.306 wire, 68 coils, 23.00"
600985 RH, 4.50" ID, 0.331 wire, 63 coils, 22.13"
600995 LH, 4.50" ID, 0.331 wire, 63 coils, 22.13"

Miscellaneous:

502290 Tube Astragal
521261 Felt Tape, 2"
502061 Guide Runner
502520 Draft Stop
504300 Touch-up Paint, Evergreen
504301 Touch-up Paint, Sunset Orange
504302 Touch-up Paint, Polar Blue
504303 Touch-up Paint, Royal Blue
504305 Touch-up Paint, Desert Tan
504306 Touch-up Paint, Continental Brown
504307 Touch-up Paint, Garnet
504308 Touch-up Paint, Iced White
50430A Touch-up Paint, Cedar Red

Operators:

600550 Direct Drive Chain Hoist
603911 Reduced Drive Chain Hoist
600531 Shaft Extension Kit
601355 5' Shaft Extension Kit